

Effect of Processing Parameters on the Earing and Mechanical Properties of Strip Cast Type 3004 Al Alloy

O.S. Es-Said, A. Zeihen, M. Ruprich, J. Quattrocchi, M. Thomas, K.H. Shin, M. O'Brien, D. Johansen, W.H. Tjoe, and D. Ruhl

Electrical resistivity, superficial hardness, tensile testing, and quantitative metallography techniques were used in this study. The strip cast type 3004 aluminum alloy received sixteen different thermomechanical treatments before cups were drawn. The top edges of the drawn cups were not flat. Rather there were high points or ears with valleys between them. The homogenization temperature varied from 510 to 621 °C at 24 h. Some samples received an additional 426 °C/24 h homogenization anneal. Most specimens were rolled along the longitudinal direction of the as-cast material, and some were rolled in the transverse direction. Most samples were recrystallized at 454 °C for 24 h in addition to the homogenization treatment. Some were recrystallized for 168 h. All samples were subsequently rolled to 0.33 mm for cup drawing and percent earing determination. The percent earing results of some samples were less than 1.5%, but the mechanical strength was also lowered. The high-temperature recrystallization anneal of 454 °C was the controlling factor in determining the earing and mechanical strength of the final rolled sheet.

Keywords

beverage can stock aluminum 3004, mechanical anisotropy (earing), precipitation, recrystallization

1. Introduction

IN THE DEEP drawing cup formation step of aluminum sheet metal, undulations on the rim of the formed cup may be found. High points, which have a scalloped appearance around the top edge of the cup, are called ears, and the general phenomenon is known as earing (Ref 1, 2). The scallops, or ears, must be removed to present a smooth flat upper lip on the cup. This leads to cup trimming prior or subsequent to wall ironing, with an increase in production costs and material waste (Ref 2). Can manufacturers have tightened the earing requirement (material waste) from 5% in 1980 to the present 3%, or preferably less (Ref 3). Accordingly, control of earing (mechanical anisotropy) plays an important role in processing of aluminum sheet and strip for deep drawing applications. The ears of two main forms: four ears at 0/90° to the rolling direction, associated with cube-type texture, and four ears at 45° to the rolling direction, associated with deformation-type textures.

The majority of alloys used are presently semicontinuously, direct chill (DC) casting billets that are processed by hot and cold rolling to the final gauge. Type 3004 aluminum alloy constitutes a large proportion of the rolled aluminum product worldwide due to its use in beverage cans. The presence of magnesium provides strength, and the distribution of Al₆Mn and other particles stabilizes the structure during processing. Interest has been shown in developing alloys that take advantage of the high solute supersaturations that may be achieved through rapid solidification in the continuous casting method and subsequently processed by cold rolling and on-line anneal-

ing, thus eliminating the hot rolling step and providing an attractive short-cut from the liquid metal state to the final can stock. The aim of this work is to study the effect of varying the homogenization temperature, rolling mode, and recrystallization duration on the earing level and mechanical strength of the final rolled sheet of strip cast type 3004 aluminum alloy.

2. Background

Casting method, homogenization treatment, recrystallization anneal, and mode of rolling are processing parameters that affect the earing behavior and mechanical strength of the final rolled sheet of drawn and ironed beverage can bodies.

2.1 Casting Method

The principal difference between alloys produced by strip casting and those produced by DC casting is the higher level of solute supersaturation and smaller primary intermetallic size in the former. Chen, Morris, and Das (Ref 4) systematically compared the earing behavior of aluminum alloy 3004 in the strip cast and DC cast states. They indicated that the strip cast material is essentially devoid of the 0/90° earing component in the annealed state. The small grain size, reduction in the amount of grain growth, and the high supersaturation content of the strip cast material, leading to dynamic precipitation during annealing, suppresses the formation of a strong cube texture.

2.2 Homogenization

Homogenization is critical in reducing the degree of solute supersaturation, in changing the shape and size of the intermetallic particles and consequently increasing the kinetics of recrystallization, in altering the shape of the recrystallized grains, and in reducing galling. Merchant and Morris (Ref 2) indicated that a strip cast aluminum alloy 3004 homogenized between 510 and 621 °C encounters no galling during the wall ironing of a cup formed from the web. Accordingly, the homogenization temperatures in this study were chosen to range from 510 to 621 °C.

O.S. Es-Said, A. Zeihen, M. Ruprich, J. Quattrocchi, M. Thomas, K.H. Shin, M. O'Brien, D. Johansen, W.H. Tjoe, and D. Ruhl, Mechanical Engineering Department, Loyola Marymount University, Los Angeles, California, 90045.

2.3 Softening Anneal (Recovery and Recrystallization)

In previous work by Es-Said and Morris (Ref 5, 6) on the same alloy system used in this study, one set of samples was homogenized at 580 °C for 25 h and furnace cooled. The samples were then cold worked to 90% reduction thickness and annealed at nine isotherms for 25 h. The percentage of 45° earing of cups drawn from these softened samples progressively decreased from about 6% when annealed at 232 °C to less than 0.5% when annealed at 454 °C. These results are in accord with the observations of Orsund and Nes (Ref 7), who indicated that, at low recrystallization temperatures, nucleation of recrystallized grains initiate from subgrains in the outer periphery of the deformation zones surrounding large intermetallic particles, and the resulting recrystallization texture is similar to the deformed matrix. However, at high recrystallization temperatures, nucleation initiates from the core region of the deformation zones, and the recrystallization texture is nearly random. Accordingly, recrystallization of 454 °C was chosen for all the thermomechanical processes used in this study.

2.4 Rolling Mode

In a recent study by Nicol et al. (Ref 8), a commercial-type 3004 aluminum alloy was rolled and annealed to yield a strong cube component and was further rolled at different rolling reductions at five different angles from 0° (along the initial rolling direction) to 90° (along the transverse direction). The transverse rolling mode after annealing indicated a slightly stronger cube texture than the longitudinal rolling mode. Accordingly, in this study, some samples were rolled in the longitudinal mode and others in the transverse mode.

3. Experimental

Strip cast (stationary mold) AA 3004 plate, obtained from Vereingte Aluminum-Werke, Germany, of 300 × 300 × 12 mm were used in this study. The spectrographic analysis of the strip cast 3004 aluminum alloy is given in Table 1. Two fabricating schedules were carried out; in the first, the homogenization treatments were varied, and in the second, primarily the recrystallization time and percentage of cold work were varied.

In the first fabricating schedule, six homogenizing treatments (preheating steps) were produced (Fig. 1). The homogenization temperatures and times were 510 °C/24 h, ~565 °C/24 h, and ~621 °C/24 h. These single homogenization steps were called condition Ia, IIa, and IIIa, respectively. The same initial steps were repeated, followed by a second homogenization step of ~426 °C/24 h. These double homogenizations were called conditions Ib, IIb, and IIIb, respectively. All of these samples were cold worked along the longitudinal direction of the as-cast material. The six homogenization steps were re-

peated, and the samples were cold worked along the transverse direction of the as-cast material. The samples that were rolled in the transverse direction were called conditions IVa to VIb. Samples Ia to VIb of 12 mm thickness were cold rolled to 0.5% reduction in thickness (Fig. 1). The samples with a thickness of 0.6 mm were then annealed at 454 °C for 24 h. Samples were quenched in water at times from 1 to 24 h.

The kinetics of softening were studied by using hardness measurements (Rockwell superficial 15T) and optical metallography. The particle structure of the samples was examined after etching in a perchloric acid solution. The grain structures were revealed by using a fluoboric acid anodize using a polarized light. The mean grain diameter, D , was measured by the line interception method according to the relation:

$$D = \frac{L_T}{PM}$$

where L_T is the total test-line length; M is the magnification; and P is the number of grain boundary intersections. Electrical resistivity measurements (a standard four-terminal probe method) were used to monitor the changes in solute solid concentration of the alloy. The addition of a solute to an otherwise pure metal raises the electrical resistivity, whereas if the solute is removed from solid solution by precipitation (or segregation), the electrical resistivity decreases because a precipitate is not as effective an electron scatterer as is the solute in solid solution. The electrical resistivity of 3004 aluminum alloys depends mainly on the manganese solid solution concentration (Ref 9, 10). The stress-strain characteristics were determined at room temperature at a constant crosshead speed of 1.3 mm/min using a screw-driven Instron machine in a uniaxial tension mode. Following recrystallization for 24 h, all of the samples were cold rolled to 45% reduction in thickness. The samples with a thickness of 0.33 mm were baked at 210 °C for 10 to 20 min, deep drawn, and the earing percentage of the cups was calculated using the following formula:

$$\% \text{ earing} = \frac{(H_p - H_v) \times 100}{(H_p + H_v)/2}$$

where H_p is the distance between the bottom of the cup and the peak of ear, and H_v is the distance between the bottom of the cup and the valley of the ear.

In the second fabricating schedule, conditions E1 to E4 were produced (Fig. 2a to d). In condition E1 (Fig. 2a), the magnified factor is the time of recrystallization anneal, 168 h. The E2 condition resembles the E1 condition, except for the rolling schedule, where a 95% cold work prior to recrystallization and a final 45% cold work were changed to 80 and 85%, respectively (Fig.

Table 1 Chemical composition of type 3004 aluminum alloy

Mn	Mg	Si	Fe	Zn	Composition, wt %					
					Cu	Cr	Ti	Ni	Pb	Sn
1.05	1.04	0.25	0.43	<0.10	<0.05	<0.05	<0.05	<0.05	<0.05	<0.05

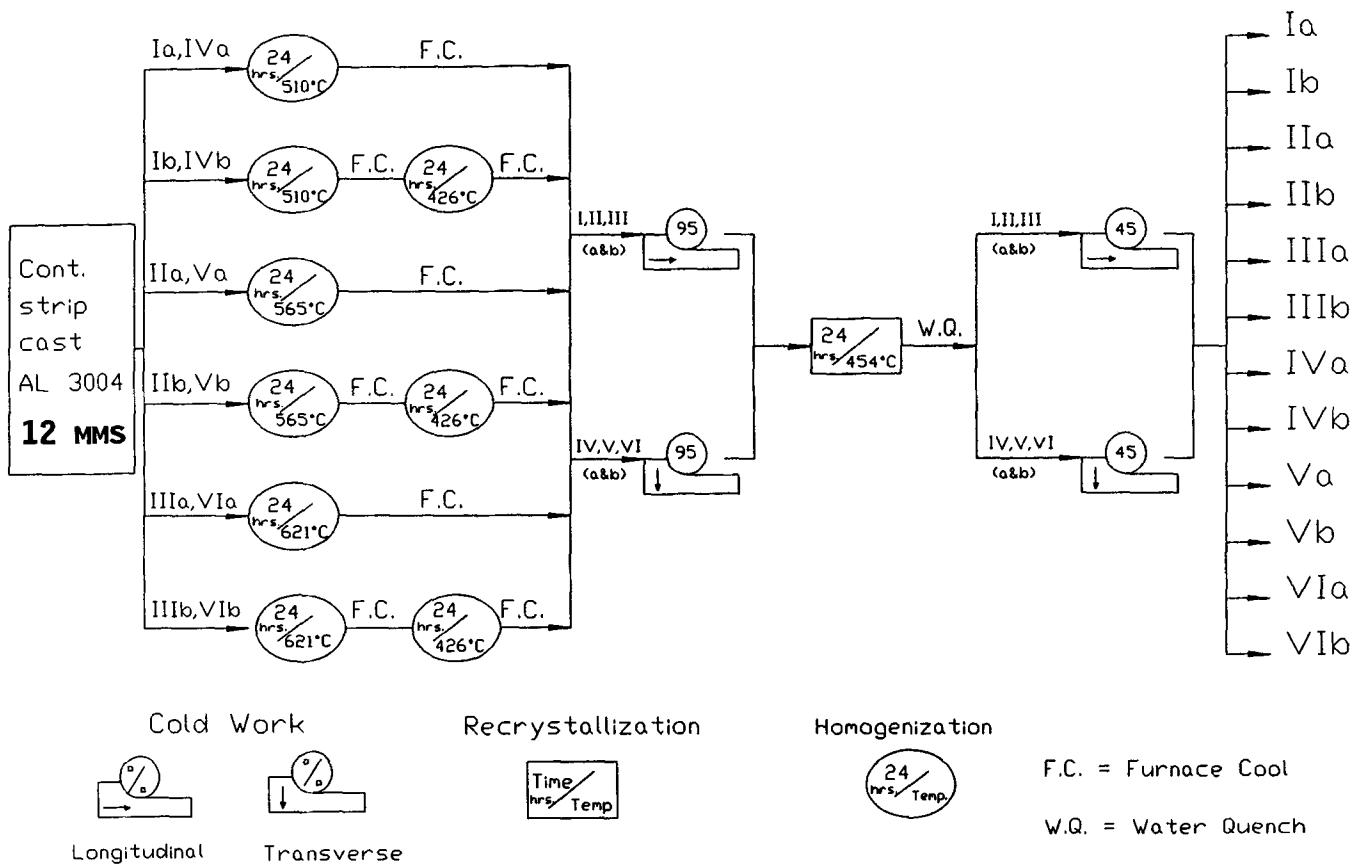

Fig. 1 Thermomechanical process to study the effect of homogenization treatments on the mechanical anisotropic behavior of AA 3004 strip cast aluminum alloy

Homogenization at 510°C/24 hours → 95% Cold Work
 → Recrystallization at 454°C/168 hours → 45% Cold Work till
 0.033 cms

Figure 2(a): Condition E1.

Homogenization at 510°C/24 hours → 80% Cold Work
 → Recrystallization at 454°C/168 hours → 85% Cold Work till
 0.033 cms

Figure 2(b): Condition E2.

Homogenization at 599°C/24 hours → 80% Cold Work
 → Recrystallization at 454°C/168 hours → 85% cold till
 0.033 cms

Figure 2(c): Condition E3.

Homogenization at 599°C/24 hours → 95% Cold Work
 → Recrystallization at 454°C/240 hours → 45% Cold Work
 till 0.033 cms

Fig. 2 Thermomechanical process of conditions E1 to E4. Material starting thickness: 1.2 cm

2b). The E3 condition resembles the E2 condition, except for a higher homogenization anneal of 599 °C instead of 510 °C (Fig. 2c). In the E4 condition, the magnified factors are a high-temperature homogenization anneal, 599 °C, and an extended recrystallization annealing time, 240 h (Fig. 2d). All of the E1 to E4 conditions were cold worked along the longitudinal direction.

4. Results and Discussion

All of the thermomechanical processes were composed of four steps: a homogenization treatment, recrystallization (cold working and annealing), and a final cold work.

4.1 Effect of Homogenization and Rolling Mode

The independent variables in the first fabricating schedule are the homogenization temperature (510, 565, and 621 °C) and the rolling mode (0° or 90° to the as-cast rolling direction) (Fig. 1). The dependent variables are the percentage earing and the mechanical strength of the final rolled sheet.

The degree of the solute supersaturation change, as determined by measuring electrical resistivity, after different homogenization treatments and two rolling modes is shown in Table 2. The supersaturation level appears to be independent of the rolling mode. Solute supersaturation in solid solution increases with increasing homogenization temperature, being the

Table 2 Effect of processing on electrical resistivity of strip cast type 3004 aluminum alloy+

Processing	Electrical resistivity, $\mu\Omega \cdot \text{cm}$	
	Longitudinal rolling	Transverse rolling
As-cast + 90% cold work	6.53	...
As-cast + 510 °C for 24 h + 95% cold work	4.39(a)	4.48(b)
As-cast + 510 °C for 24 h + 426 °C for 24 h + 95% cold work	4.19(c)	4.18(d)
As-cast + 565 °C for 24 h + 95% cold work	4.94(e)	4.80(f)
As-cast + 565 °C for 24 h + 426 °C + 95% cold work	4.60(g)	4.80(h)
As-cast + 621 °C for 24 h + 95% cold work	5.22(i)	5.04(j)
As-cast + 621 °C for 24 h + 426 °C for 24 h + 95% cold work	4.87(k)	4.94(j)

Note: All homogenization treatments were carried out for 24 h. (a) Condition Ia. (b) Condition IVa. (c) Condition Ib. (d) Condition IVb. (e) Condition IIa. (f) Condition Va. (g) Condition IIb. (h) Condition Vb. (i) Condition IIIa. (j) Condition VIa. (k) Condition IIIb. (l) Condition VIb

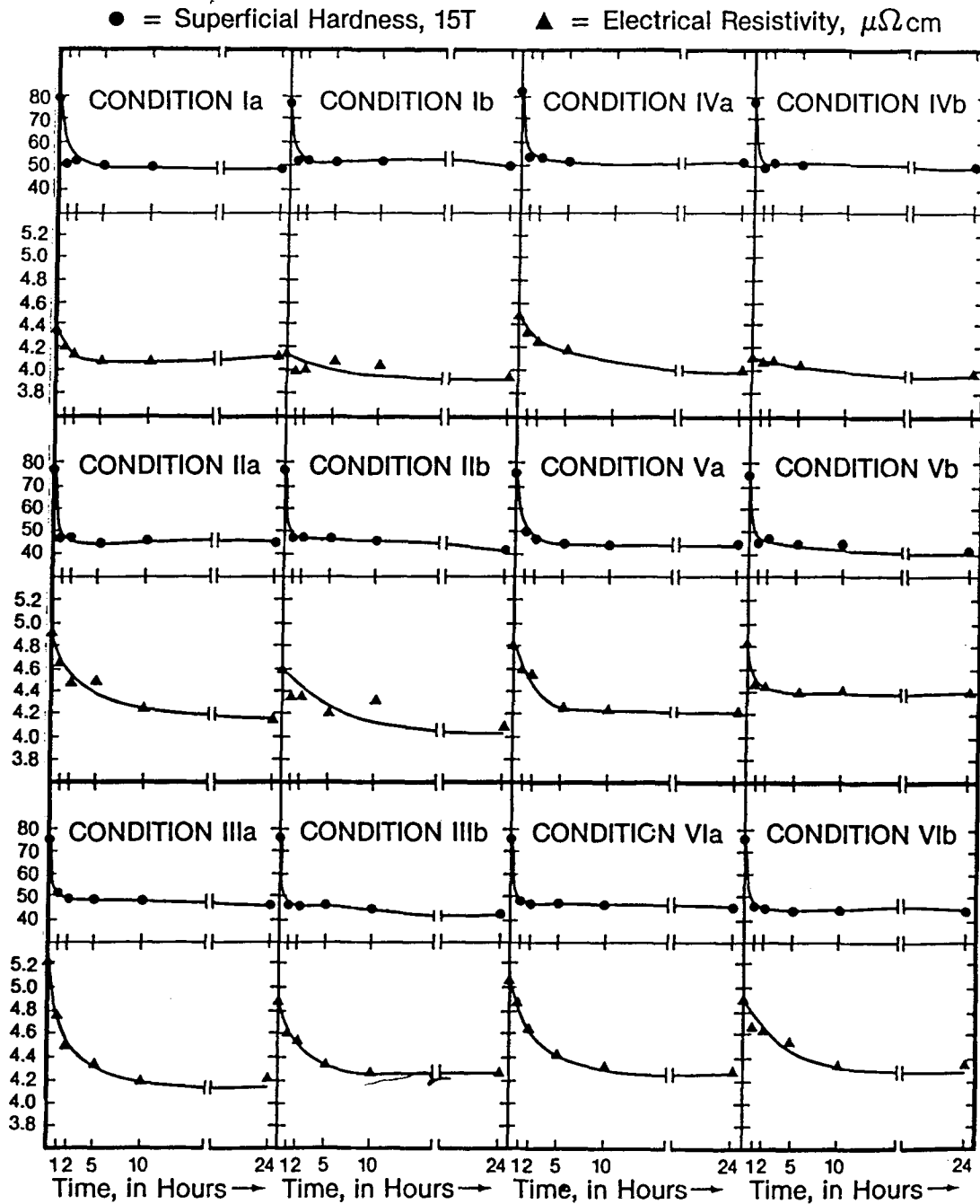

Fig. 3 Superficial hardness and electrical resistivity changes versus annealing time

lowest at $4.39 \mu\Omega \cdot \text{cm}$ at 510°C and the highest at $5.22 \mu\Omega \cdot \text{cm}$ at 621°C . Also, supersaturation decreases with a double homogenization step as compared to a single homogenization step. For example, the electrical resistivity after a homogenization of 510°C was $4.39 \mu\Omega \cdot \text{cm}$ and dropped to $4.19 \mu\Omega \cdot \text{cm}$ after 510°C followed by a 426°C treatment. These results are in accord with the work of Li et al. (Ref 11), who indicated that, in the high temperature homogenization step (607°C for 6 h) and in the double homogenization steps (607°C for 6 h + 454°C for 6 h), globulization and break up of the intermetallic eutectics occurred, whereas in the low-temperature homogenization step (454°C for 6 h) the intermetallic particles were not affected and loss of solute supersaturation was attributed to solid-state precipitation of $\text{Al}_6(\text{Mn,Fe})$ and Al_6Mn . The softening behavior of the high-temperature homogenization step and the double homogenization steps was rapid compared to the low-temperature homogenization step (Ref 11). In this study, however, the different homogenization temperatures with different initial degrees of solute supersaturation levels did not ex-

hibit any effect on softening behavior. The decomposition behavior and softening characteristics of conditions Ia to VIb are shown in Fig. 3, where the materials in all of the conditions were fully recrystallized after 1 h of annealing at 454°C , regardless of a low level of dynamic precipitation (conditions Ia, Ib, IVa, and IVb), a medium level of dynamic precipitation accompanying recrystallization (conditions IIa, IIb, Va, and Vb), or a relatively high dynamic precipitation level (conditions IIIa, IIIb, VIa, and VIb). The same result is confirmed in Fig. 4, where the yield stress (0.2% offset) and the ultimate stress rapidly drop to 68.9 MPa (10 ksi) and around 151.6 to 172.3 MPa (22 to 25 ksi), respectively, in about 1 h.

The discrepancy in the kinetics of softening between Li et al (Ref 11) and this study can be explained by the Hornbogen-Koster-Stuwe (HKS) model (Ref 12). In this model, the interaction of precipitation and recrystallization depends on the temperature. At high temperatures, recrystallization precedes precipitation. At intermediate temperatures, interference between both phenomena occurs, and at lower temperatures, pre-

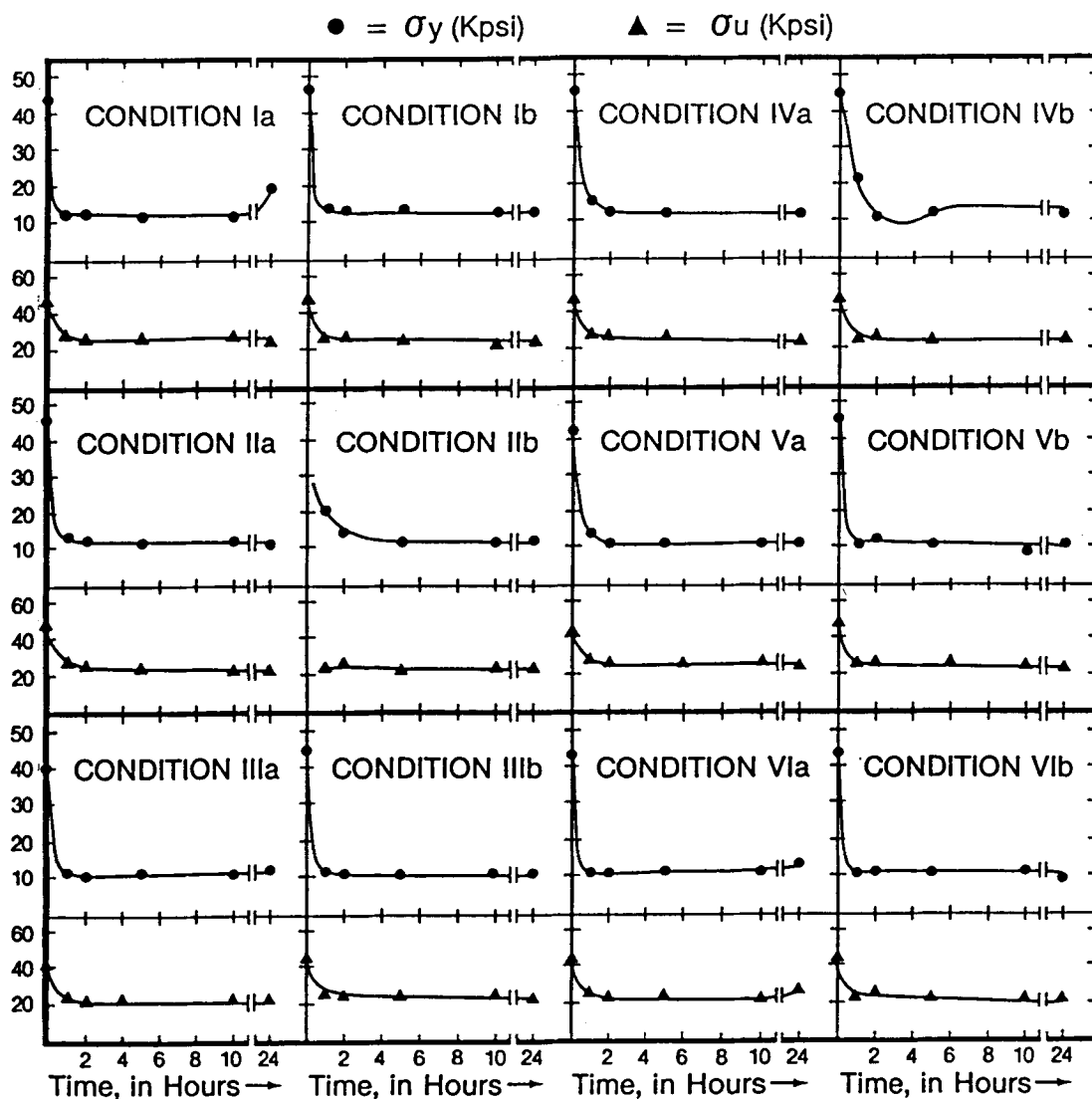

Fig. 4 Yield stress and ultimate tensile stress changes versus annealing time. 1 ksi = 6.89 MPa

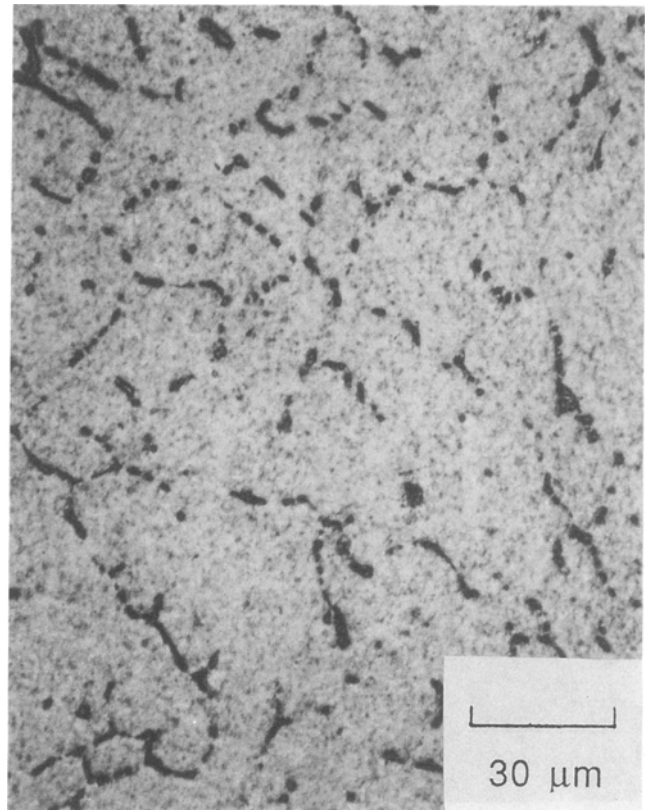
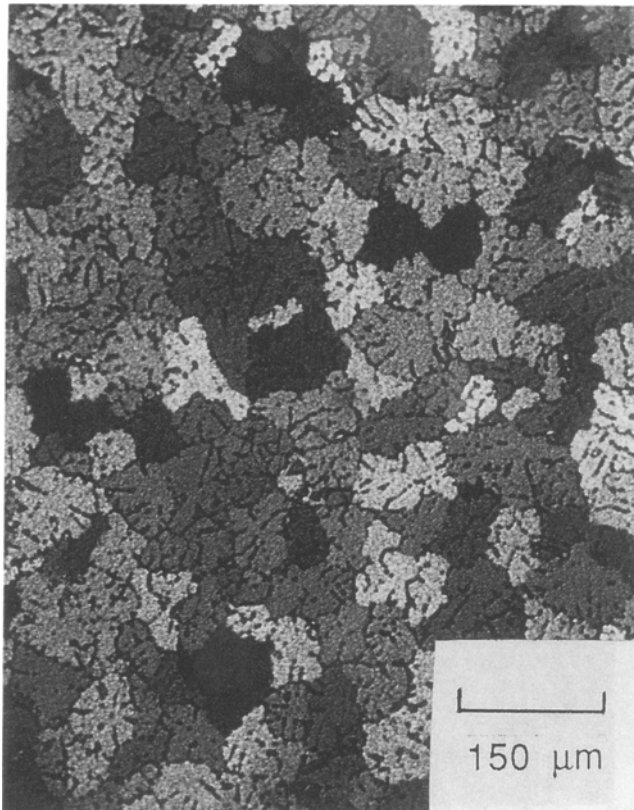

Fig. 5 Grain structure and particle structure of type 3004 aluminum alloy at two magnifications. Both images are in Condition I, as homogenized.

precipitation precedes recrystallization. In this study, the high-temperature recrystallization anneal of 454 °C caused recrystallization to precede precipitation, and the initial particle structure and solute supersaturation level prior to annealing did not interfere with the completion of recrystallization.

The grain sizes of the initial homogenized states, conditions Ia to VIb, are between 45 and 60 μm, with a progressive increase of 5 to 10 μm from a single to a double homogenization treatment. However, the average recrystallization grain sizes of all conditions after 95% cold work and 454 °C/24 h were 10 to 15 μm without any significant or consistent variations relating to the initial homogenization. The grain structure was uniform and equiaxed. In Fig. 5, the grain structure and particle structure of condition I as homogenized is shown. The intermetallic eutectic cast structure, mainly Al_6 (Mn,Fe) and Al_{12} (Mn,Fe)₃ Si₂ particles are dispersed, coarsened, and globularized. In Fig. 6, the grain and particle structure of condition I as recrystallized is shown. The recrystallized grains are fine, and precipitation of fine dispersoids has occurred.

All materials from conditions Ia to VIb were finally rolled to the H19 temper (Fig. 1), where cups were drawn and their mechanical strengths were evaluated. The range of values for mechanical strength and earing level specified by the beverage can manufacturers for 3004 aluminum alloy is given in Table 3. Table 4 shows the almost identical mechanical properties of the final rolled sheet of conditions Ia to VIb. The ultimate strength

Table 3 Strength and earing specifications of alloy 3004 used for beverage can manufacture

Ultimate tensile strength, ksi	39-43
Yield strength (0.2% offset), ksi	36-41
Total elongation, %	1-2
Earing level	Less than 3%

Note: 1 ksi = 6.89 MPa

and yield strength fell below the minimum requirement by about 20%, but the total percent elongation requirement was met. The low values of the ultimate and yield strength of the final rolled sheet indicate that the 45% reduction in thickness is not sufficient to completely eliminate the recrystallized structure. The microstructure of all of the final rolled sheet revealed a retained recrystallized microstructure. For example, in Fig. 7, where the grain and particle structure of a sample from condition I in the H19 temper is shown, the grain boundaries are distinct. The average grain size for conditions Ia to VIb were in the range of 25 to 30 μm in length and 10 to 15 μm in width, without consistent variations between conditions.

The sheet was subsequently baked, and cups were drawn. The deep drawing characteristics of condition Ia to VIb, with a low earing level less than 3% but with a high fracture percentage (indicating mechanical embrittlement), are shown in Table

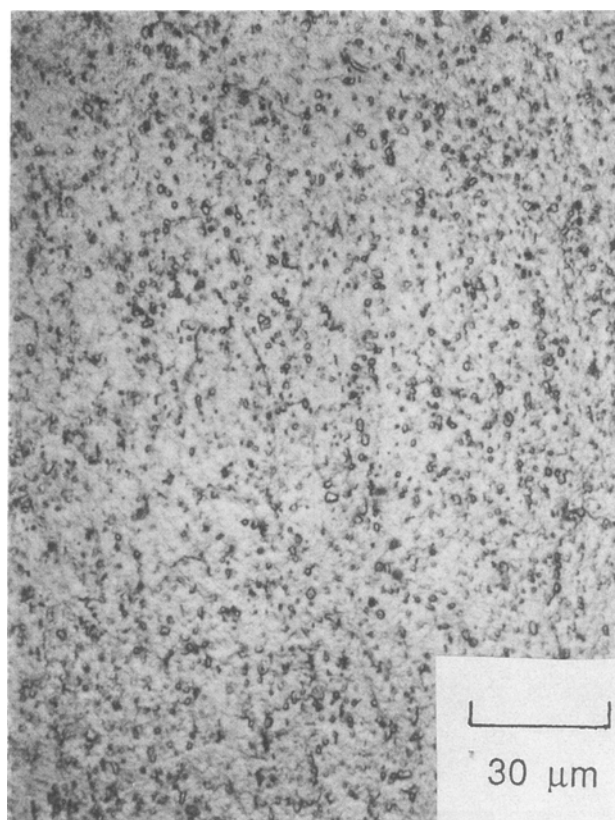
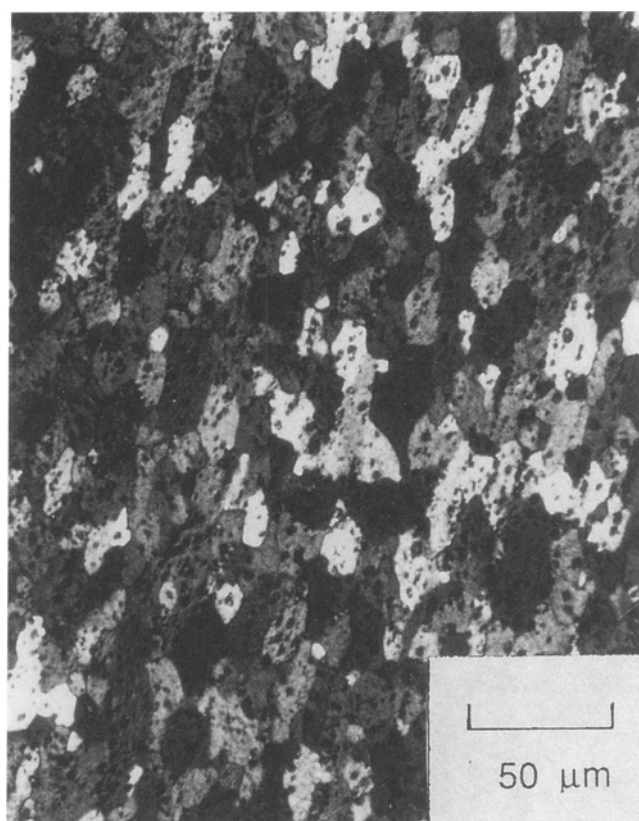

Fig. 6 Grain structure and particle structure of type 3004 aluminum alloy at two magnifications. Both images are in Condition I, as recrystallized (454 °C/24 h) after 95% cold work.

Table 4 Mechanical properties of final rolled sheet

Condition	Ultimate tensile strength, ksi	Yield strength (0.2% offset), ksi	Total elongation, T
Ia	35	32.4	1.5
Ib	33.5	32.1	1.5
IIa	34.8	33.1	1.2
II(b)	33.0	31.0	1.6
III(a)	35.0	33.0	1.4
III(b)	33.6	31.8	1.1
IV(a)	34.8	33.0	1.3
IV(b)	34.5	31.7	1.8
V(a)	33.1	31.4	1.2
V(b)	33.4	32.3	2.3
VI(a)	34.9	33.5	2.9
VI(b)	33.8,32.1	2.1	

Note: 1 ksi = 6.89 MPa

5. From the drawn cups, it can be noted that low-temperature homogenization does not favor a lower percentage of earing as compared to a higher temperature homogenization (compare Ia versus IIIa, Ib versus IIIb, and IVa versus VIa). This result is not in accord with the observations of other studies (Ref 13, 14).

It is well established that the recrystallization behavior of the material has a profound effect with regard to controlling its subsequent earing behavior (Ref 11, 15, 16). In this study, although the homogenization (preheating) treatments varied systematically from 510 to ~621 °C, including single and double homogenization steps, the subsequent high-temperature recrystallization anneal of 454 °C virtually rendered all of the recrystallized sheet almost identical in grain structure and mechanical strength. Accordingly, when the sheet was rolled and deep drawn, the earing percentage was almost identical regardless of the initial homogenization step or rolling mode.

The embrittlement of the finally rolled sheet might have been caused by the formation of a large volume fraction of fine dispersoids during the recrystallization anneal (Fig. 3).

4.2 Effect of Extended Recrystallization and Extent of Deformation

Conditions E1 to E4 were processed to magnify one or more of the four processes: homogenization, cold work plus anneal (recrystallization), and final cold work to determine the controlling factor on the dependent variables, namely percentage earing and mechanical strength. The mechanical properties of the final rolled sheet are shown in Table 6, and the deep drawing characteristics are shown in Table 7.

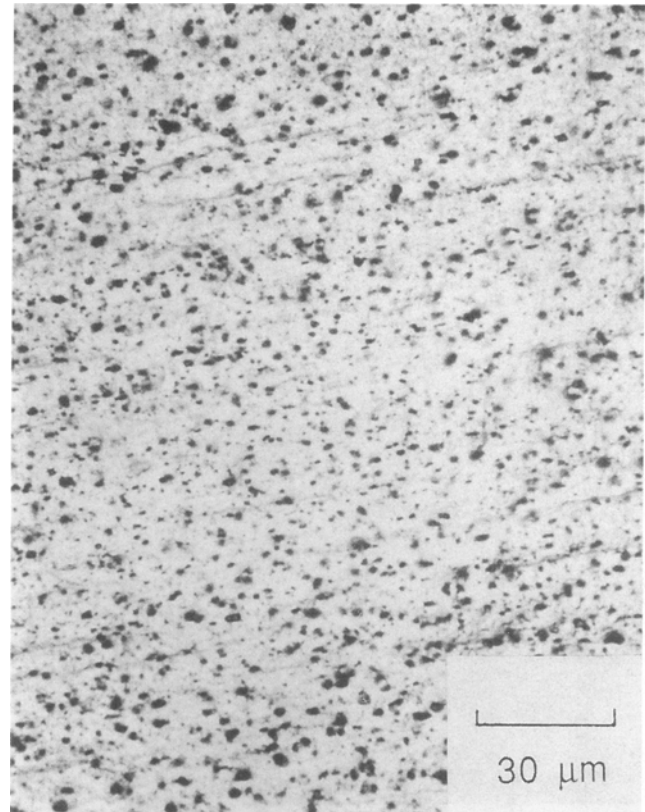
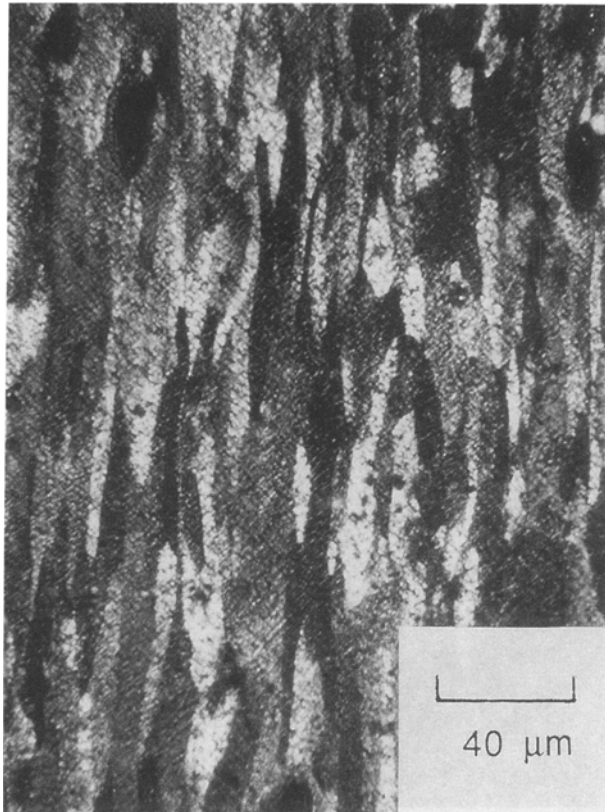

Fig. 7 Grain and particle structure of condition I as finally rolled (45% cold work) to 0.33 mm

Table 5 Deep drawing characteristics of conditions Ia to VIb

Condition	Percent earing of drawn cups(a)	Fracture percent(b)	Average percent earing(a)
Ia	1.6	75 (3 out of 4)	1.6
Ib	2.3 2.3 2.1	40 (2 out of 5)	2.2
IIa	...	100 (1 out of 1)	Fracture
IIb	...	100 (3 out of 3)	Fracture
IIIa	1.4 1.4	0 (0 out of 2)	1.4
IIIb	1.7	75 (3 out of 4)	1.7
IVa	2.1 2.1	0 (0 out of 2)	2.1
IVb	1.5 1.7	0 (0 out of 2)	1.6
Va	...	100 (3 out of 3)	Fracture
Vb	...	100 (2 out of 2)	Fracture
VIa	1.6 1.4	0 (0 out of 2)	1.5
VIb	...	100 (2 out of 2)	Fracture

(a) All ears were at 45° to the rolling direction. (b) Number of fractured cups out of the total trials

In E1, a low-temperature single homogenization step at 510 °C, the magnified factor was the long time during the recrystallization anneal (Fig. 2a). The ultimate strength and yield strength were lower than all of the corresponding strengths in conditions Ia to VIb due to the longer time of the recrystallization anneal. The percentage earing (1.4%) was equivalent to those obtained in conditions Ia, IIIa, and VIa, and the total percent elongation was not significantly high (1.7%).

Condition E2 was similar to condition E1, except for changing the rolling schedule, which was used in all previous conditions. In conditions Ia to VIb and E1, the final cold work was kept to a minimum (45% reduction in thickness) to minimize the effect of the deformation texture components in promoting 45° ears. However, the mechanical strength always fell below the minimum requirements (Table 3). In E2, the cold work prior to recrystallization was decreased from 95% to 80%, and the final cold work was increased from 45% to 85%. Although the mechanical strength was above the minimum requirements (Table 3), the earing percentage increased to 5.6%.

In condition E3, which is similar to condition E2 except for increasing the homogenization temperature from 510 to 599 °C, the mechanical strength was above the minimum requirement, and the percentage earing dropped slightly from 5.6% in E2 to 5.0% in E3. This result again indicates that, contradictory to other studies (Ref 13, 14), a low-temperature homogenization does not favor a lower percentage of earing compared to a higher temperature homogenization. This confirms that the high-temperature recrystallization anneal of 454 °C resulted in

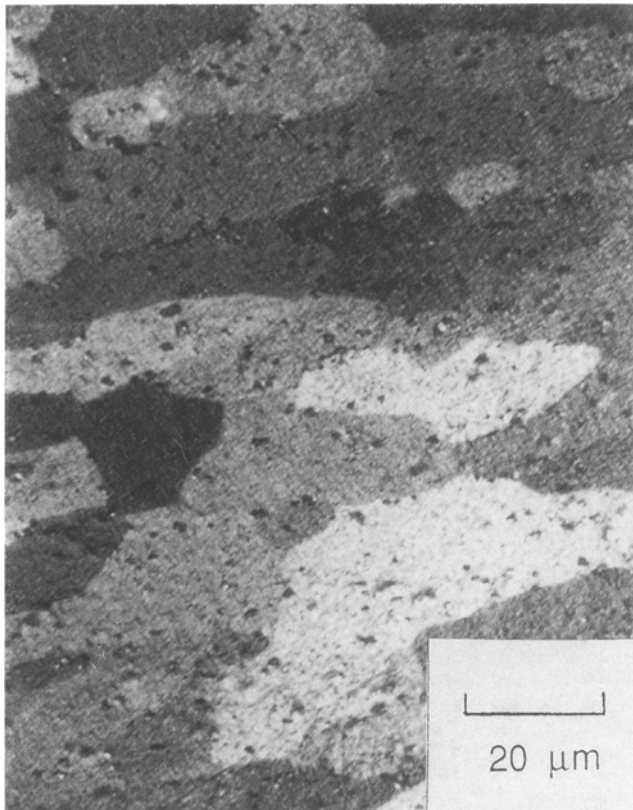

Fig. 8 The grain structure of E1 as recrystallized

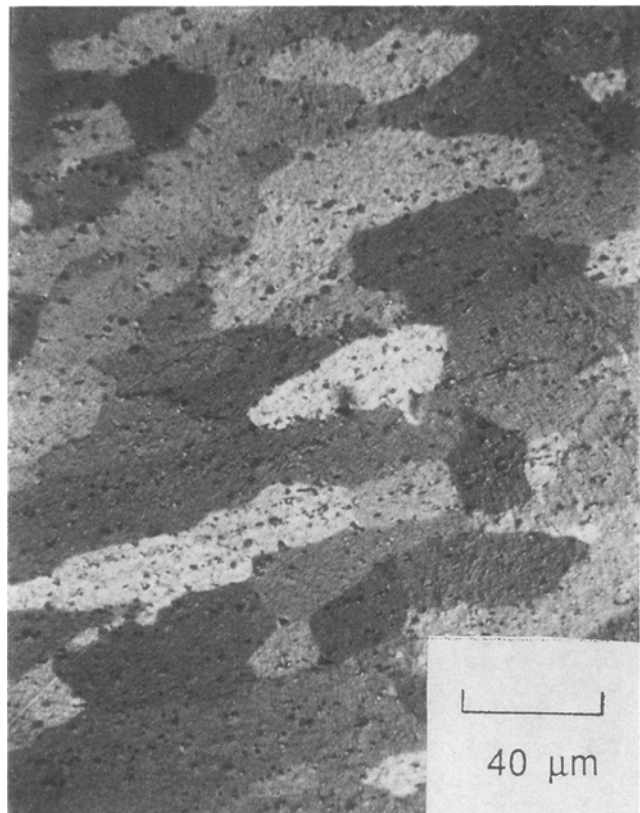

Table 6 Mechanical properties of final rolled sheet

Condition	Ultimate strength, ksi	Yield strength (0.2% offset), ksi	Total elongation, %
E1	30.9	29.5	39.1
E2	41.5	39.1	2.4
E3	43.5	40.2	1.9
E4	32.1	30.8	1.7

Note: 1 ksi = 6.89 MPa

conditions E2 and E3 having almost identical recrystallization behavior, mechanical strength, and subsequent earing behavior regardless of the initial homogenization step.

In conditions E4, the cold work schedule was again similar to conditions Ia to VIb and to condition E1 in that the final cold work was 45% reduction in thickness. The magnified factors were a high-temperature homogenization step (599 °C) and an overextended time (240 h) during the recrystallization anneal. The mechanical strength together with the ductility were inferior to E2 and E3; however, the percentage of earing dropped to less than 2%.

The grain structure of conditions E1 to E4 after recrystallization at 454 °C for 168 h (E1 to E3) and 240 h (E4) were similar, with an average grain size of 30 μm, although some grains extended to over 100 μm (Fig. 8 and 9). In conditions E1 and E4, where a 45% final cold work was given, similar to condi-

Table 7 Deep drawing characteristics of conditions E1 to E4

Condition	Percent earing of drawn cups(a)	Fracture percent(b)	Average percent earing(a)
E1	1.4	67 (2 out of 3)	1.4
E2	5.4 5.7 (0 out of 2)	0	5.6
E3	4.5 5.1 5.1 5.1	33 (2 out of 6)	5.0
E4	1.8	67 (2 out of 3)	1.8

(a) All ears were at 45° to the rolling direction. (b) Number of fractured cups out of the total trials

tions Ia to VIb, a retained recrystallized microstructure occurred. In conditions E2 and E3, where 85% final cold work was given, the recrystallized microstructure was completely smeared off (Fig. 10).

In conditions Ia to VIb, the recrystallized grain structure was homogeneous, with an average size of 10 to 15 μm (95% cold work + 454 °C/24 h). In conditions E1 and E4 (95% cold work + 454 °C/168 h and 240 h, respectively), the recrystallized grain structure was inhomogeneous, with some large grains (>100 μm) and with an average grain size of 30 μm. However, all of these conditions after the final roll (45% cold

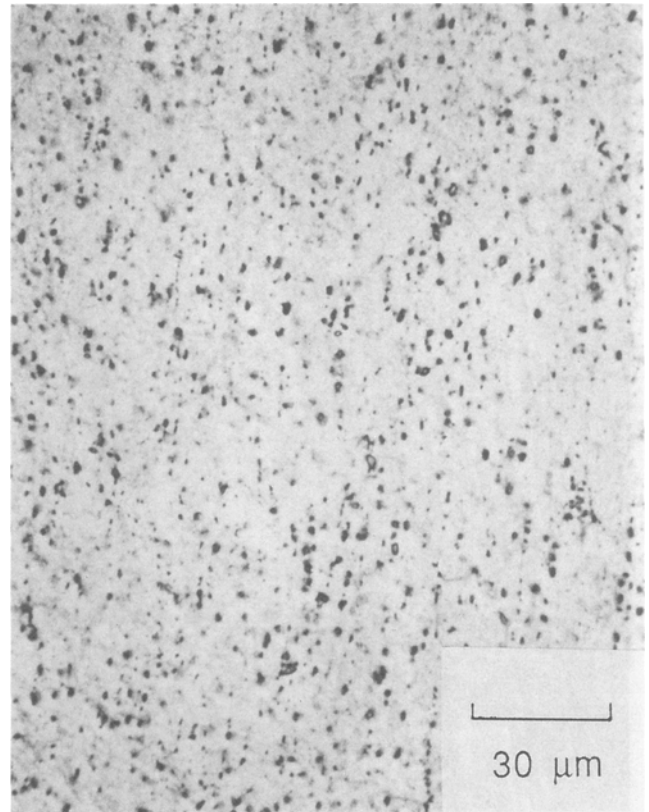
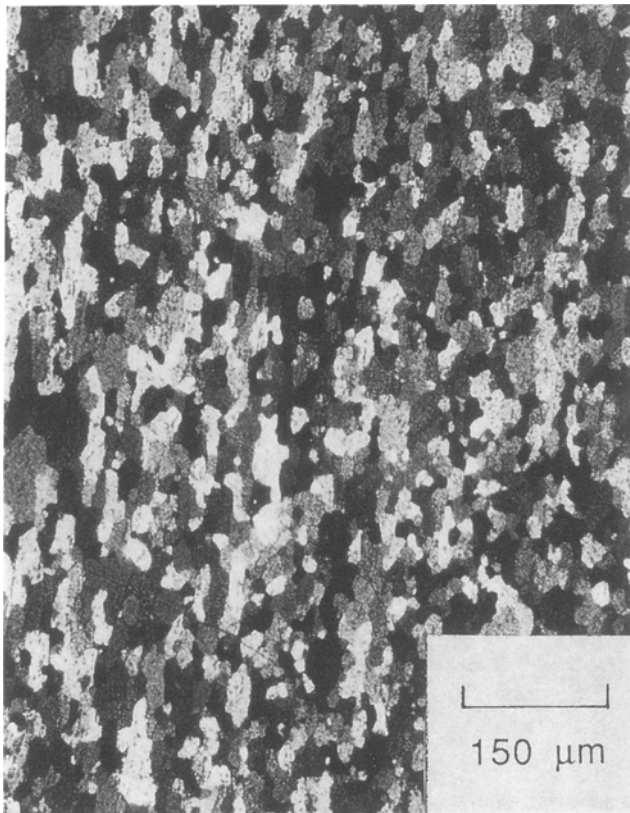

Fig. 9 Grain and particle structure of E3 as recrystallized

work) had a similar earing percentage; compare Table 5 and 7. This implies that doubling (or more) of the recrystallized grain size prior to the final roll did not promote the cube component and lower the 45° earing behavior.

Similar to the first fabricating schedule, a high fracture percentage of the drawn cups occurred (Table 7) due to the formation of a large volume fraction of fine dispersoids during the extended recrystallization annealing time. The electrical resistivity of E1, E2, E3, and E4 after the extended recrystallization anneals were 3.99, 3.87, 3.92, and 4.22 $\mu\Omega \cdot \text{cm}$, respectively, indicating a further drop in solute supersaturation content.

5. Summary and Conclusions

In the first fabricating schedule, 12 thermomechanical treatments were carried out on the strip cast type 3004 aluminum alloy, where the homogenization (preheating) treatments were varied systematically from a low temperature of 510 °C to a high temperature of 621 °C, including single and double homogenization steps (Table 2). In this alloy system, homogenization between 510 and 621 °C provides the requirements for rapid nucleation and growth of recrystallized grains. These requirements are (1) the reduction in solute supersaturation content, (2) reduction of impurity microsegregation effects, and (3) the break up and coarsening of the intermetallic particles, which in turn are potent sites for nucleation of recrystallization nuclei. The subsequent high-temperature recrystallization an-

neal of 454 °C, after 95% cold work, was the controlling factor in the sense that the recrystallization kinetics, the recrystallized grain structure, recrystallized grain size, and mechanical strength of all the conditions were virtually the same regardless of the initial homogenization step, rolling mode, or dynamic precipitation effects. Accordingly, the mechanical strength and mechanical anisotropy (earing) of all of the conditions after the final cold roll were almost identical.

In the second fabricating schedule, the above-mentioned controlling factor of the high-temperature recrystallization anneal is confirmed, where conditions E1 and E4 on the one hand (454 °C, after 95% cold work) and condition E2 and E3 on the other hand (454 °C, after 80% cold work) had similar mechanical strength and mechanical anisotropy (earing) based on the recrystallization anneal regardless of the initial homogenization step.

From the results of this study, the following conclusions are drawn. A single-step homogenization between 510 and 621 °C or a double-step homogenization of these temperatures followed by 426 °C produces virtually the same effect on the mechanical strength and mechanical anisotropy (earing) if they are followed by a large deformation (80 to 95% cold work) and a high-temperature recrystallization anneal. The earing behavior obtained was less than 3% and in some instances less than 1.5%. The total percent elongation was within the acceptable limits. However, the strength parameters (yield strength and ultimate strength) were about 20% less than the acceptable parameters.

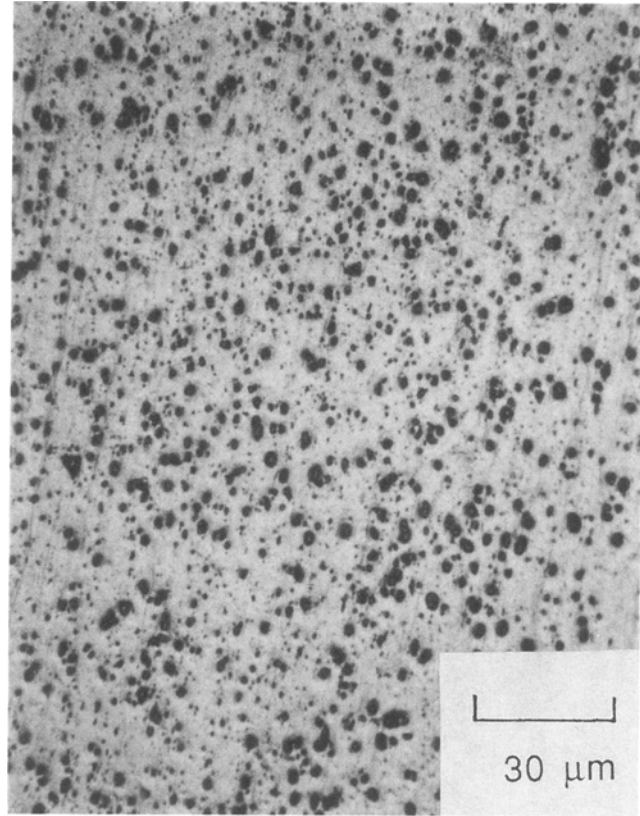
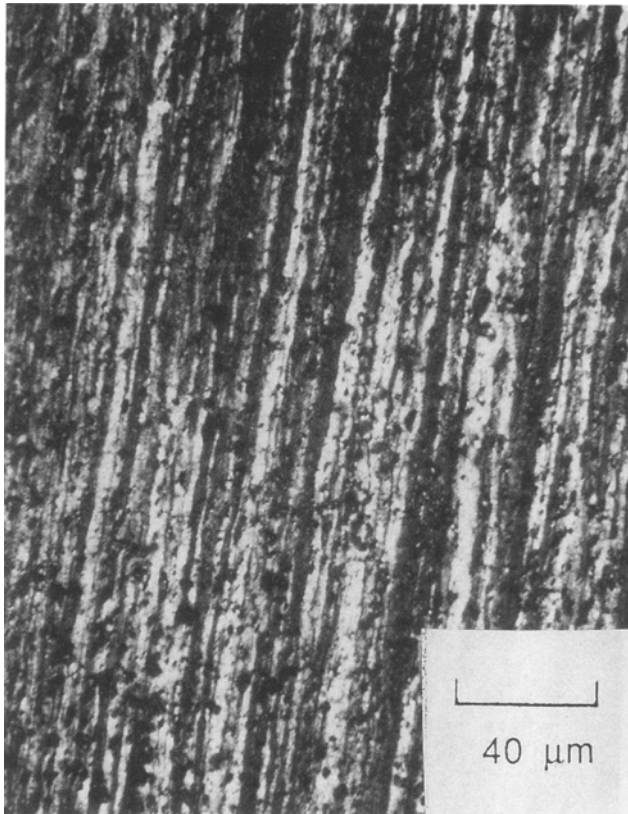

Fig. 10 The grain and particle structure of E3 as finally rolled to 0.33 mm

Conditions (E1 to E4) indicated that a minimum amount of cold work greater than 45% is needed in the final roll to impart the acceptable desired strength levels. Conditions (E1 to E4) also indicated that grain growth of recrystallized grains prior to the final roll does not promote the cube component and reduce the 45° earing behavior in the strip cast type 3004 aluminum alloy. Embrittlement of the finally rolled sheet might have been caused by the formation of a large volume fraction of fine dispersoids during the extended recrystallization anneals.

Acknowledgements

The authors would like to thank Professor J.G. Morris, University of Kentucky, and Logan Aluminum, Russellville, Kentucky, for their help in drawing the cups and measuring the earing level. Special thanks to Dr. J. Callinan, Dean T. Calder, and Mrs. Olga Rivera for their help in preparing the manuscript.

References

1. J.C. Blade, *Earing Control in Aluminum Alloys*, H.D. Merchant and J.G. Morris, Ed., AIME, 1985, p 1-16
2. H.D. Merchant and J.G. Morris, Continental Can Company, UK Patent 2123319A, 1984
3. S.E. Naess, *Earing and Texture in Strip-Cast 3004 Type Alloys*, J.G. Morris, H.D. Merchant, E.J. Westerman, and P.L. Morris, Ed., TMS, 1993, p 275-298
4. L. Chen, J.G. Morris, and S.K. Das, *The Effect of Cooling Rate During Casting on the Structure and Mechanical Property Behavior of AA 3004 Aluminum Alloy*, H.D. Merchant, D.E. Tyler, and E.H. Chia, Ed., TMS, 1989, p 269-284
5. O.S. Es-Said and J.G. Morris, *Deformation and Annealing Textures Produced in Strip Cast 3004 Aluminum Alloy*, T. Sheppard, Ed., The Institute of Metals, London, 1986, p 333-338
6. O.S. Es-Said, "Effect of Particles on the Recrystallization Characteristics of Aluminum-1% Manganese-1% Magnesium (3004) Alloy," Ph.D. thesis, University of Kentucky, 1985
7. R. Orsund and E. Nes, Effect of Particles on Recrystallization Textures in Aluminum-Manganese Alloys, *Scr. Metall.*, Vol 22, 1988, p 665-669
8. B. Nicol, A. Oscarsson, and P. Bate, *The Effect of Rolling Direction upon the Recrystallization Texture of Al-1.0% Mn-1.2% Mg Alloy*, T. Chandra, Ed., TMS, Wollongong, Australia, 1990, p 423-428
9. O.S. Es-Said and J.G. Morris, *A Method to Calculate the Resistivity of Strip Cast 3000 Series Al Alloys Based on Their Nominal Solute Content*, J.F. Bussiere, J.-P. Concahlin, C.O. Ruud, and R.E. Green, Jr., Ed., Plenum Press, Montreal, 1986, p 271-279
10. T.C. Sun, J.G. Morris, and H.D. Merchant, Effect of Mn Super-saturation on Texture and Earing Behavior of Aluminum Alloys, *Earing Control in Aluminum Alloys*, H.D. Merchant and J.G. Morris, Ed., AIME, 1985, p 79-98
11. Z. Li, J.G. Morris, S.X. Ding, and C.X. Li, *Effect of Homogenization on Recrystallization Behavior of AA 3004 Aluminum Alloy*, L. Arnberg, O. Lohne, E. Nes, and N. Ryum, Ed., SINTEF, Trondheim, Norway, 1992, p 373-378
12. E. Hornbogen and U. Koster, *Recrystallization of Two Phase Alloys*, F. Haessner, Ed., Reiderer, Stuttgart, 1978, p 154-194

13. D. Teirlinck and G.M. Raynaud, Effect of Homogenization on the Behavior of Roll Cast 3004 for Can Stock, *The Effect of Cooling Rate During Casting on the Structure and Mechanical Property Behavior of AA 3004 Aluminum Alloy*, H.D. Merchant, D.E. Tyler, and E.H. Chia, Ed., TMS, 1989, p 243-258
14. A. Karlsson, A. Oscarsson, B. Lehtinen, and W.B. Hutchinson, *Influence of Homogenization on Structure and Earing in Aluminum Alloy 3004*, H.D. Merchant, J. Crane, and E.H. Chia, Ed., AIME, 1988, p 99-116
15. J. Hirsch and J. Hasenclever, Cube Texture and Earing Control in Al Sheet, *Effect of Homogenization on Recrystallization Behavior of AA 3004 Aluminum Alloy*, L. Arnberg, O. Lohne, E. Nes, and N. Ryum, Ed., SINTEF, Trondheim, Norway, 1992, p 305-310
16. O.S. Es-Said, J.G. Morris, and R.J. DeAngelis, Effect of Extended Recovery on the Recrystallization Characteristics of Flash-Annealed Strip Cast 3004 Aluminum Alloy, *Mater. Charact.*, Vol 30, 1993, p 113-125